



PARADE

PEMULWUY

HOUSE & LAND
PACKAGES



THE PEAK OF MODERN LIVING

PARADE ENJOYS
NATURAL AND PEACEFUL
SURROUNDINGS, AN
ACTIVE COMMUNITY,
AND RARE ACCESS TO
URBAN AMENITIES AND
SCENIC LANDSCAPES.

Elevated amongst 44 hectares
of parklands and neighbored
by the vast lake and picturesque
terrains of Prospect Hill, Parade
experiences the best of both
worlds - an incredible sense of
tranquility, alongside supreme
conveniences, services, and all
the touches of a Creations Home.

This is just the beautiful beginning
of a lifelong adventure.

MASTERPLAN YOUR FUTURE



- For Sale
- Under Contract
- Sold



PARADE

PEMULWUY

LOT 2-02

FAULKNER
CONTEMPORARY



LOT AREA 314m²
HOUSE AREA 251.8m²

KEY INCLUSIONS

- 2590mm high ceilings to ground floor, 2440mm to first floor
- Hybrid timber look flooring to ground floor living, dining, kitchen, entry and hallway
- 20mm stone benchtops throughout
- Miele appliances
- Dual zone ducted reverse cycle air-conditioning
- LED downlights throughout (excluding bedroom)
- Driveway, clothesline and landscaping to front and rear yards



Artist impression only.

NOTE: Alfresco size and structure is subject to authority approval

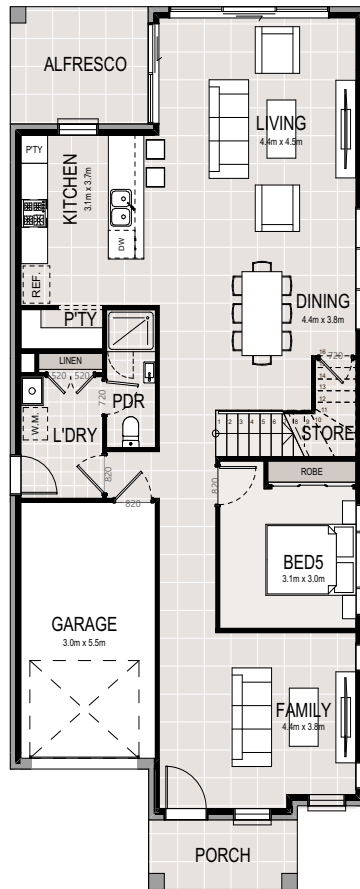

GROUND FLOOR PLAN

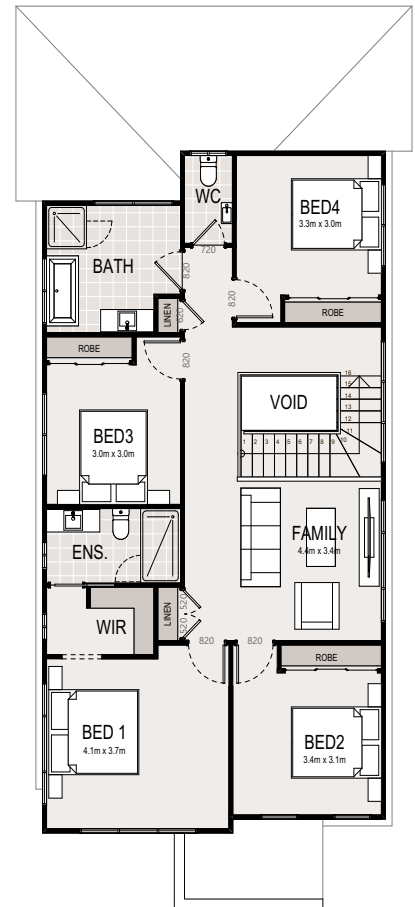

FIRST FLOOR PLAN

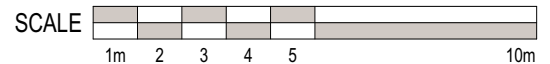



PARADE

PEMULWUY

LOT 2-04

FAULKNER
MODERN



LOT AREA 314m²
HOUSE AREA 253m²

KEY INCLUSIONS

- 2590mm high ceilings to ground floor, 2440mm to first floor
- Hybrid timber look flooring to ground floor living, dining, kitchen, entry and hallway
- 20mm stone benchtops throughout
- Miele appliances
- Dual zone ducted reverse cycle air-conditioning
- LED downlights throughout (excluding bedroom)
- Driveway, clothesline and landscaping to front and rear yards



Artist impression only.

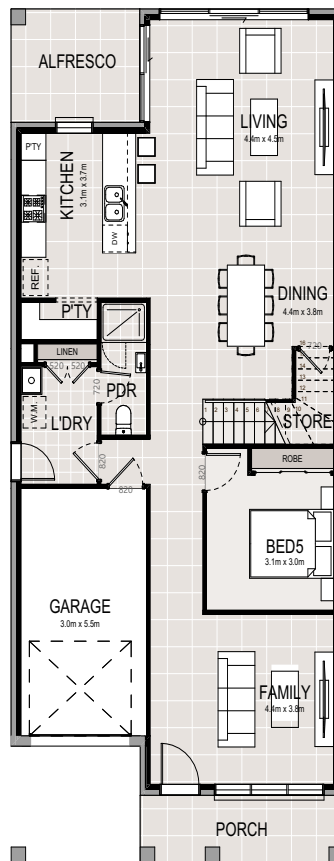

GROUND FLOOR PLAN

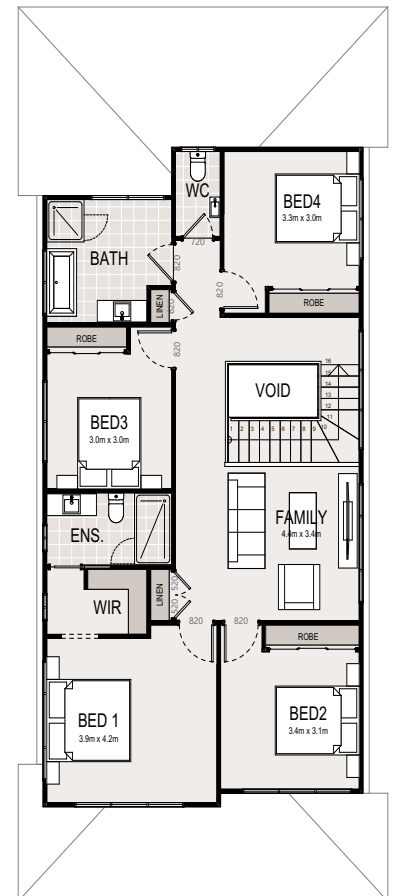

FIRST FLOOR PLAN



PARADE

PEMULWUY

LOT 3-02

FAULKNER
TRADITIONAL



LOT AREA 323m²
HOUSE AREA 251.8m²

KEY INCLUSIONS

- 2590mm high ceilings to ground floor, 2440mm to first floor
- Hybrid timber look flooring to ground floor living, dining, kitchen, entry and hallway
- 20mm stone benchtops throughout
- Miele appliances
- Dual zone ducted reverse cycle air-conditioning
- LED downlights throughout (excluding bedroom)
- Driveway, clothesline and landscaping to front and rear yards



Artist impression only.

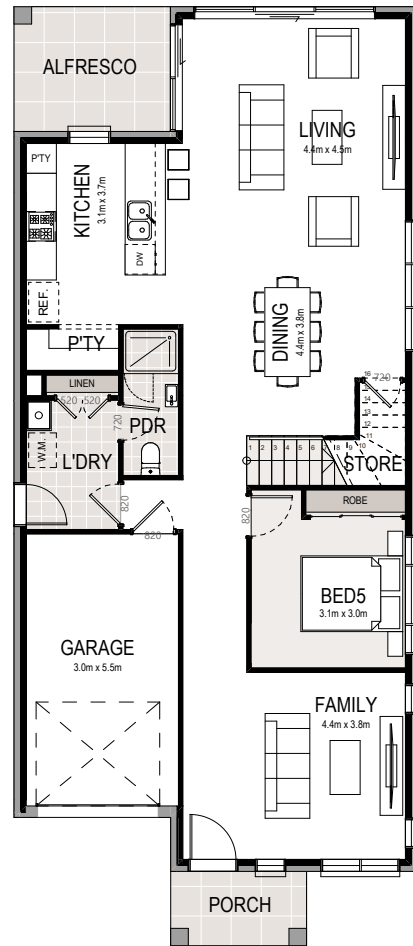

GROUND FLOOR PLAN

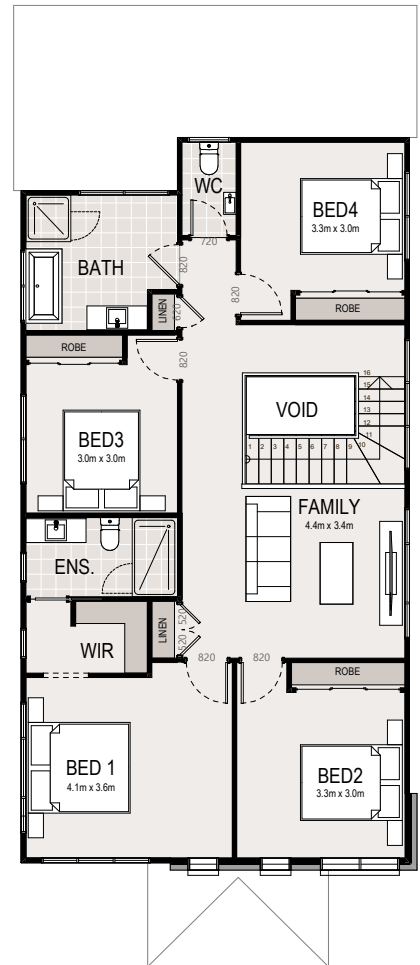

FIRST FLOOR PLAN



PARADE

PEMULWUY

LOT 3-03

FAULKNER
MODERN



LOT AREA 326m²
HOUSE AREA 250.32m²

KEY INCLUSIONS

- 2590mm high ceilings to ground floor, 2440mm to first floor
- Hybrid timber look flooring to ground floor living, dining, kitchen, entry and hallway
- 20mm stone benchtops throughout
- Miele appliances
- Dual zone ducted reverse cycle air-conditioning
- LED downlights throughout (excluding bedroom)
- Driveway, clothesline and landscaping to front and rear yards



Artist impression only.

NOTE: Alfresco size and structure is subject to authority approval

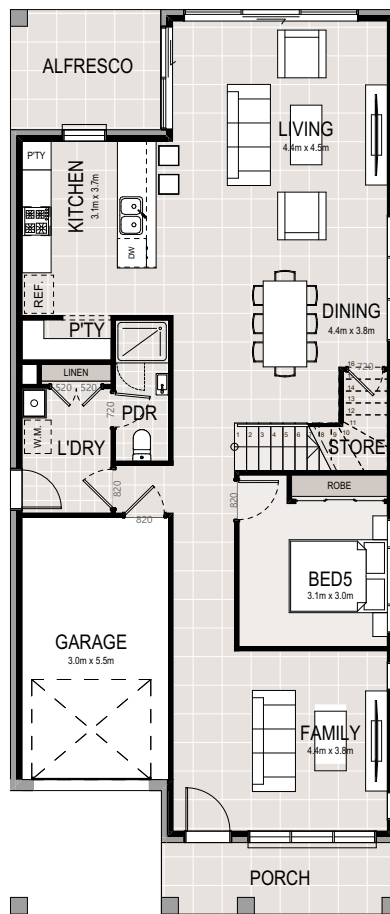

GROUND FLOOR PLAN

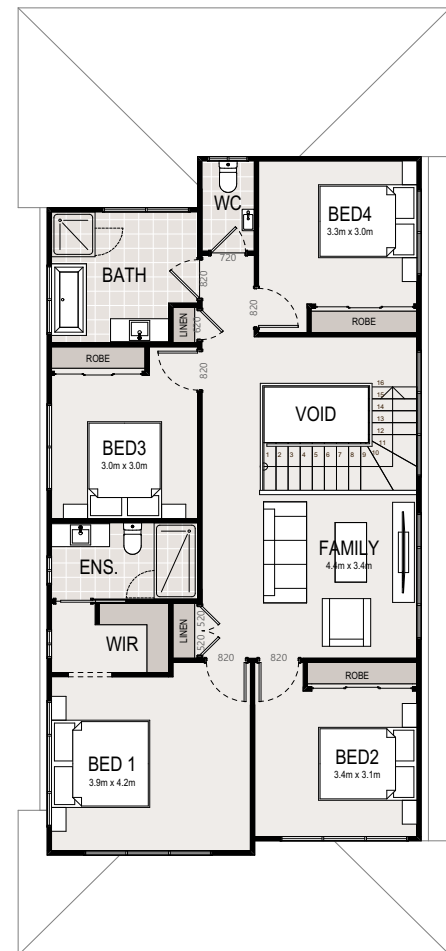

FIRST FLOOR PLAN

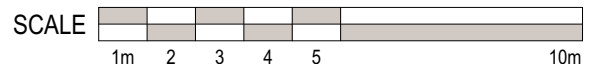

Disclaimer: These are preliminary, indicative floorplans, subject to planning and other approvals. Please note that these floorplans were produced prior to completion of construction. Location and extent of facade, elements, fittings, finishes and specifications are approximate only & subject to change without notice in accordance with the provisions of the Contract of Sale or where required for compliance, planning, building regulations, other laws or for any other reason. All images are for illustrative purposes only. The furniture depicted is not included with any sale. Prospective purchasers must make & only rely on their own assessments & seek their own professional advice in all respects. *Fixed price for standard site costs only. All designs are copyright to Creation Homes Pty Ltd. Builders Licence No. 286729C. Prepared July 2023.



PARADE

PEMULWUY

LOT 3-04

FAULKNER
HAMPTON



LOT AREA 329m²
HOUSE AREA 252.13m²

KEY INCLUSIONS

- 2590mm high ceilings to ground floor, 2440mm to first floor
- Hybrid timber look flooring to ground floor living, dining, kitchen, entry and hallway
- 20mm stone benchtops throughout
- Miele appliances
- Dual zone ducted reverse cycle air-conditioning
- LED downlights throughout (excluding bedroom)
- Driveway, clothesline and landscaping to front and rear yards



Artist impression only.

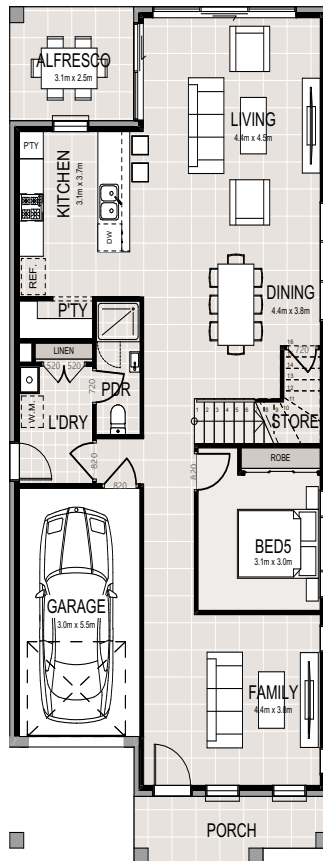

GROUND FLOOR PLAN

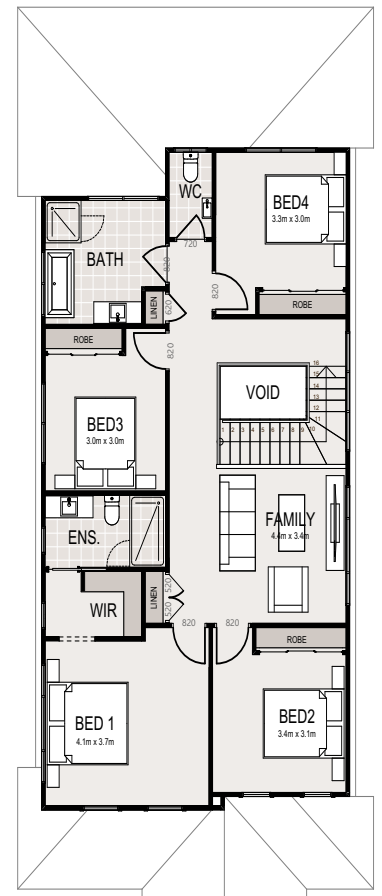

FIRST FLOOR PLAN



PARADE

PEMULWUY



Artist impression only.

LOT 3-17 A

5 3 1

LOT AREA 218m²
HOUSE AREA 192m²

KEY INCLUSIONS

- 2590mm high ceilings to ground floor, 2440mm to first floor
- Hybrid timber look flooring to ground floor living, dining, kitchen, entry and hallway
- 20mm stone benchtops throughout
- Miele appliances
- Dual zone ducted reverse cycle air-conditioning
- LED downlights throughout (excluding bedroom)
- Driveway, clothesline and landscaping to front and rear yards

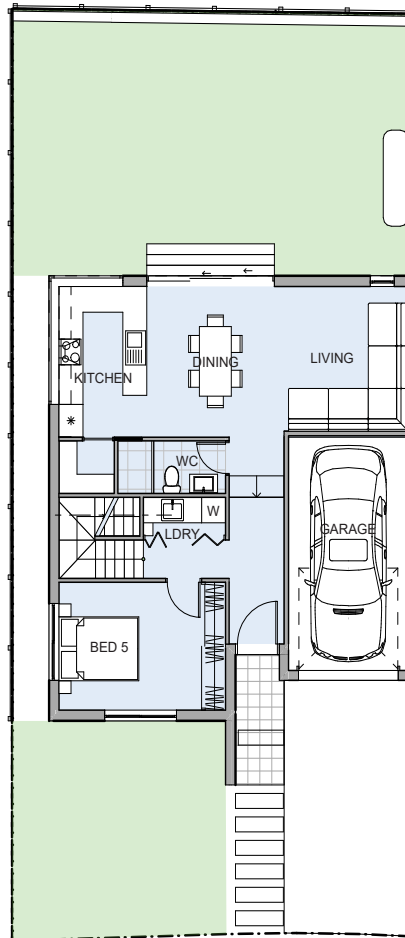

GROUND FLOOR PLAN

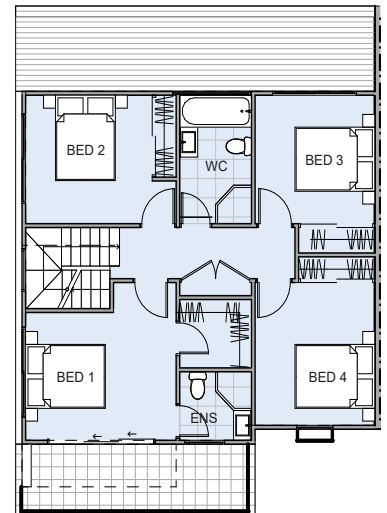

FIRST FLOOR PLAN



PARADE

PEMULWUY

LOT 4-04

DAILEY
CONTEMPORARY



LOT AREA 300m²
HOUSE AREA 207.39m²

KEY INCLUSIONS

- 2590mm high ceilings to ground floor, 2440mm to first floor
- Hybrid timber look flooring to ground floor living, dining, kitchen, entry and hallway
- 20mm stone benchtops throughout
- Miele appliances
- Dual zone ducted reverse cycle air-conditioning
- LED downlights throughout (excluding bedroom)
- Driveway, clothesline and landscaping to front and rear yards



Artist impression only.

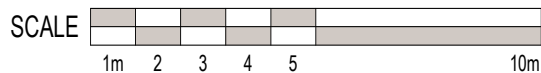
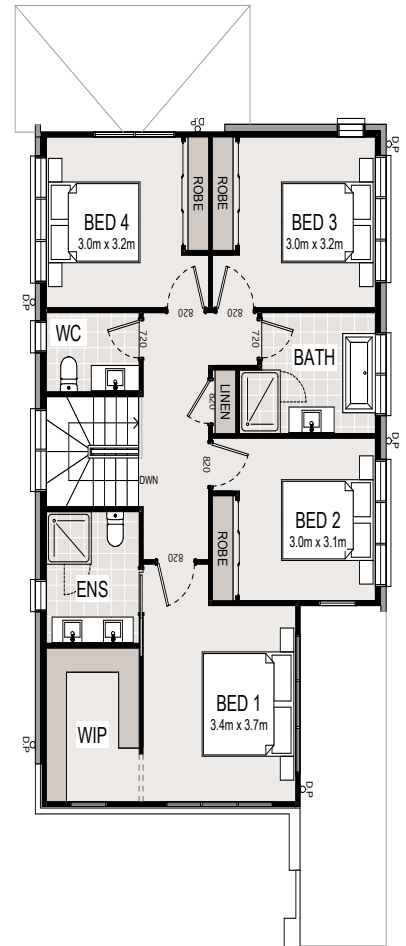
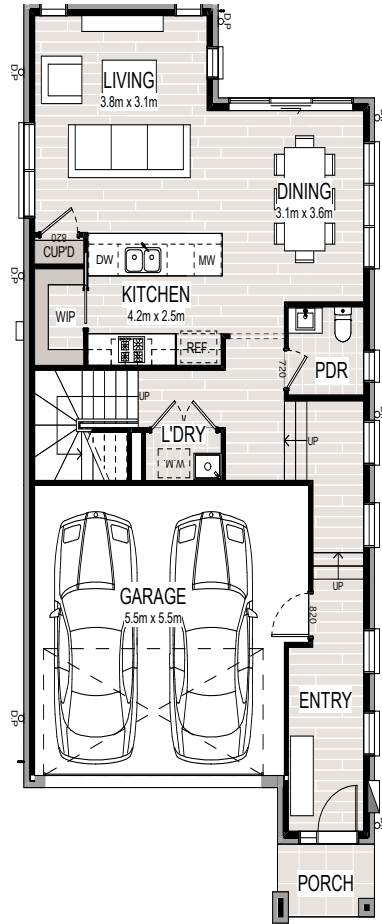



PARADE

PEMULWUY

LOT 4-05

DAILEY
TRADITIONAL



LOT AREA 536m²
HOUSE AREA 253m²

KEY INCLUSIONS

- 2590mm high ceilings to ground floor, 2440mm to first floor
- Hybrid timber look flooring to ground floor living, dining, kitchen, entry and hallway
- 20mm stone benchtops throughout
- Miele appliances
- Dual zone ducted reverse cycle air-conditioning
- LED downlights throughout (excluding bedroom)
- Driveway, clothesline and landscaping to front and rear yards



Artist impression only.

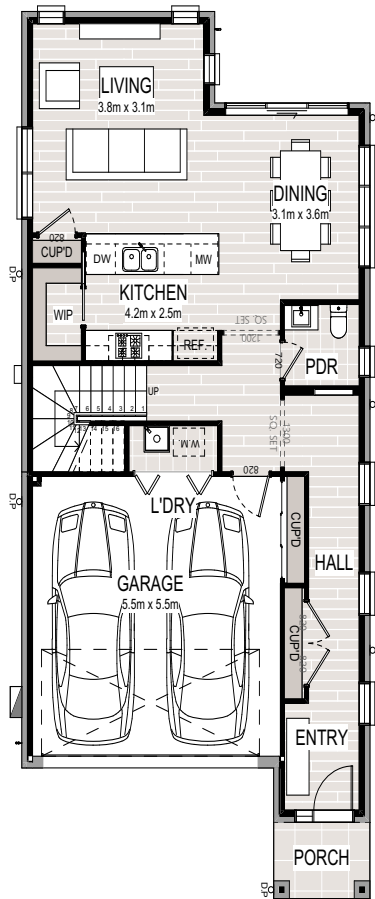

GROUND FLOOR PLAN

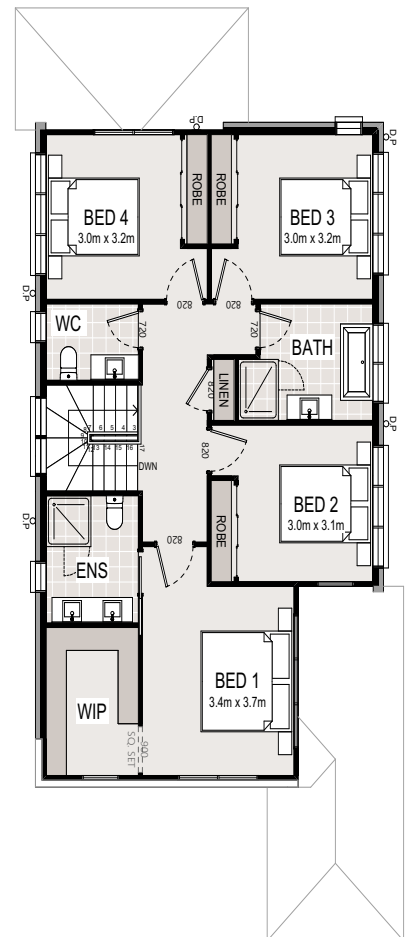

FIRST FLOOR PLAN

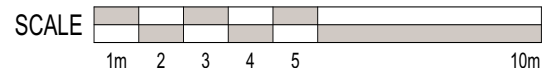



PARADE

PEMULWUY

LOT 5-02

MACLEAN
TRADITIONAL



LOT AREA 423m²
HOUSE AREA 253.55m²

KEY INCLUSIONS

- 2590mm high ceilings to ground floor, 2440mm to first floor
- Hybrid timber look flooring to ground floor living, dining, kitchen, entry and hallway
- 20mm stone benchtops throughout
- Miele appliances
- Dual zone ducted reverse cycle air-conditioning
- LED downlights throughout (excluding bedroom)
- Driveway, clothesline and landscaping to front and rear yards



Artist impression only.

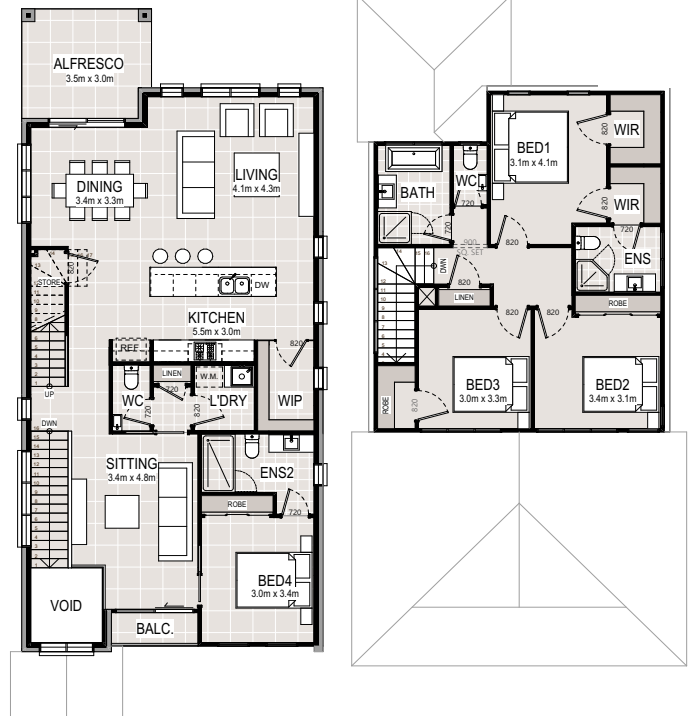

GROUND FLOOR PLAN

FIRST FLOOR PLAN

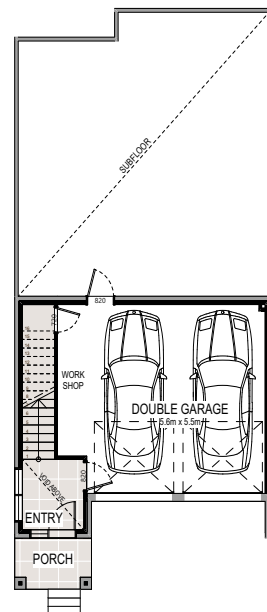

GARAGE PLAN



Disclaimer: These are preliminary, indicative floorplans, subject to planning and other approvals. Please note that these floorplans were produced prior to completion of construction. Location and extent of facade, elements, fittings, finishes and specifications are approximate only & subject to change without notice in accordance with the provisions of the Contract of Sale or where required for compliance, planning, building regulations, other laws or for any other reason. All images are for illustrative purposes only. The furniture depicted is not included with any sale. Prospective purchasers must make & only rely on their own assessments & seek their own professional advice in all respects. *Fixed price for standard site costs only. All designs are copyright to Creation Homes Pty Ltd. Builders Licence No. 286729C. Prepared July 2023.



PARADE

PEMULWUY

LOT 5-03

PARKER
CONTEMPORARY



LOT AREA 459m²
HOUSE AREA 253m²

KEY INCLUSIONS

- 2590mm high ceilings to ground floor, 2440mm to first floor
- Hybrid timber look flooring to ground floor living, dining, kitchen, entry and hallway
- 20mm stone benchtops throughout
- Miele appliances
- Dual zone ducted reverse cycle air-conditioning
- LED downlights throughout (excluding bedroom)
- Driveway, clothesline and landscaping to front and rear yards



Artist impression only.



GROUND FLOOR PLAN

FIRST FLOOR PLAN

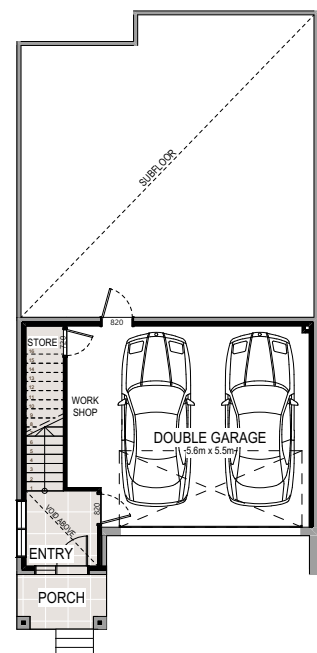

GARAGE PLAN



PARADE

PEMULWUY

LOT 5-05

MILLER
MODERN



LOT AREA 470m²
HOUSE AREA 253.68m²

KEY INCLUSIONS

- 2590mm high ceilings to ground floor, 2440mm to first floor
- Hybrid timber look flooring to ground floor living, dining, kitchen, entry and hallway
- 20mm stone benchtops throughout
- Miele appliances
- Dual zone ducted reverse cycle air-conditioning
- LED downlights throughout (excluding bedroom)
- Driveway, clothesline and landscaping to front and rear yards



Artist impression only.



GROUND FLOOR PLAN

FIRST FLOOR PLAN

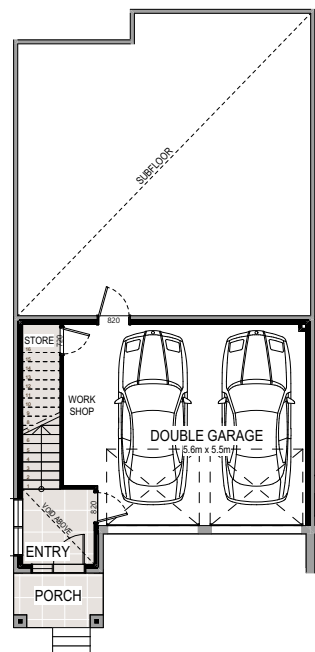

GARAGE PLAN



PARADE

PEMULWUY

LOT 5-06

MACLEAN
CONTEMPORARY



LOT AREA 475m²
HOUSE AREA 253.55m²

KEY INCLUSIONS

- 2590mm high ceilings to ground floor, 2440mm to first floor
- Hybrid timber look flooring to ground floor living, dining, kitchen, entry and hallway
- 20mm stone benchtops throughout
- Miele appliances
- Dual zone ducted reverse cycle air-conditioning
- LED downlights throughout (excluding bedroom)
- Driveway, clothesline and landscaping to front and rear yards



Artist impression only.



GROUND FLOOR PLAN

FIRST FLOOR PLAN

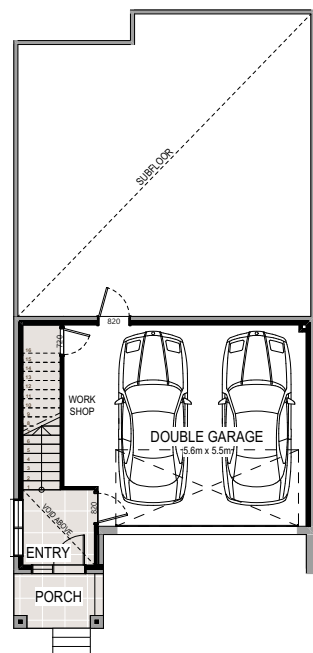

GARAGE PLAN



Disclaimer: These are preliminary, indicative floorplans, subject to planning and other approvals. Please note that these floorplans were produced prior to completion of construction. Location and extent of facade, elements, fittings, finishes and specifications are approximate only & subject to change without notice in accordance with the provisions of the Contract of Sale or where required for compliance, planning, building regulations, other laws or for any other reason. All images are for illustrative purposes only. The furniture depicted is not included with any sale. Prospective purchasers must make & only rely on their own assessments & seek their own professional advice in all respects. *Fixed price for standard site costs only. All designs are copyright to Creation Homes Pty Ltd. Builders Licence No. 286729C. Prepared July 2023.



PARADE

PEMULWUY

LOT 5-07

MILLER
TRADITIONAL



LOT AREA 470m²
HOUSE AREA 253.68m²

KEY INCLUSIONS

- 2590mm high ceilings to ground floor, 2440mm to first floor
- Hybrid timber look flooring to ground floor living, dining, kitchen, entry and hallway
- 20mm stone benchtops throughout
- Miele appliances
- Dual zone ducted reverse cycle air-conditioning
- LED downlights throughout (excluding bedroom)
- Driveway, clothesline and landscaping to front and rear yards



Artist impression only.

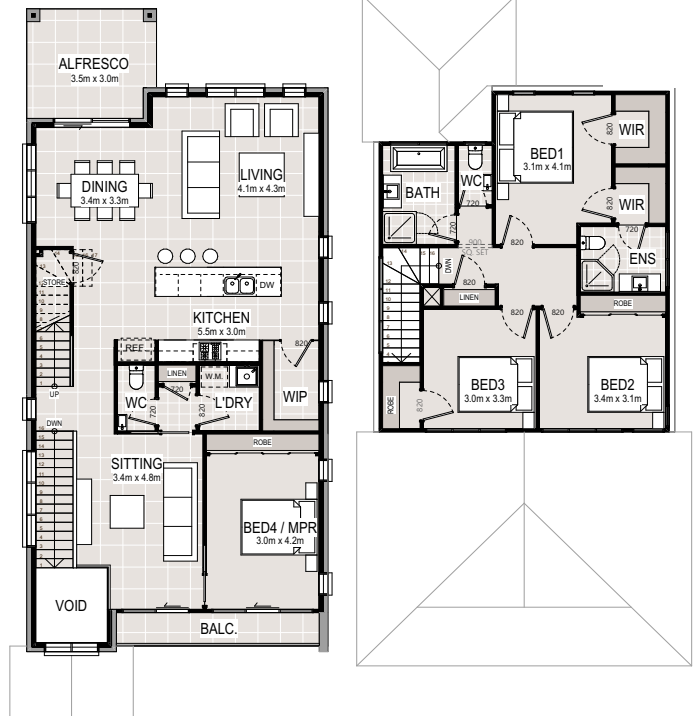

GROUND FLOOR PLAN

FIRST FLOOR PLAN

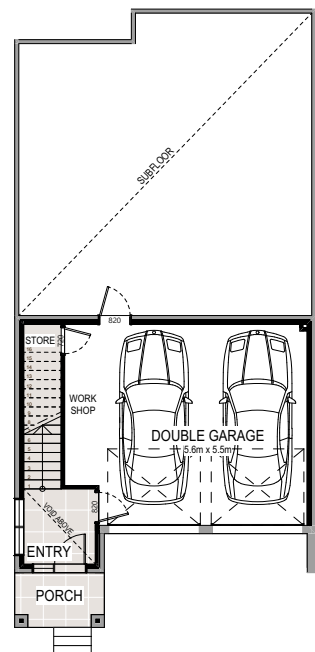

GARAGE PLAN



PARADE

PEMULWUY

LOT 5-09

PARKER
MODERN



LOT AREA 445m²
HOUSE AREA 253.6m²

KEY INCLUSIONS

- 2590mm high ceilings to ground floor, 2440mm to first floor
- Hybrid timber look flooring to ground floor living, dining, kitchen, entry and hallway
- 20mm stone benchtops throughout
- Miele appliances
- Dual zone ducted reverse cycle air-conditioning
- LED downlights throughout (excluding bedroom)
- Driveway, clothesline and landscaping to front and rear yards



Artist impression only.



GROUND FLOOR PLAN

FIRST FLOOR PLAN

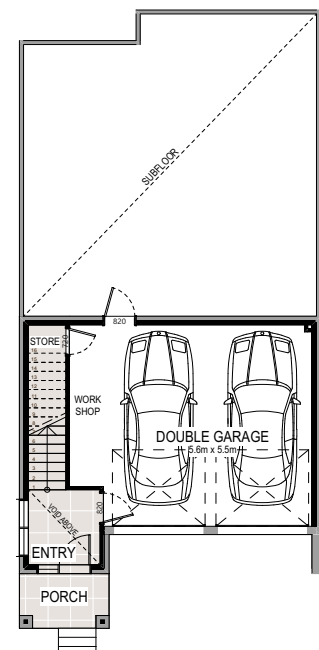

GARAGE PLAN



Disclaimer: These are preliminary, indicative floorplans, subject to planning and other approvals. Please note that these floorplans were produced prior to completion of construction. Location and extent of facade, elements, fittings, finishes and specifications are approximate only & subject to change without notice in accordance with the provisions of the Contract of Sale or where required for compliance, planning, building regulations, other laws or for any other reason. All images are for illustrative purposes only. The furniture depicted is not included with any sale. Prospective purchasers must make & only rely on their own assessments & seek their own professional advice in all respects. *Fixed price for standard site costs only. All designs are copyright to Creation Homes Pty Ltd. Builders Licence No. 286729C. Prepared July 2023.



PARADE

PEMULWUY

LOT 5-10

MACLEAN
CONTEMPORARY



LOT AREA 429m²
HOUSE AREA 253.55m²

KEY INCLUSIONS

- 2590mm high ceilings to ground floor, 2440mm to first floor
- Hybrid timber look flooring to ground floor living, dining, kitchen, entry and hallway
- 20mm stone benchtops throughout
- Miele appliances
- Dual zone ducted reverse cycle air-conditioning
- LED downlights throughout (excluding bedroom)
- Driveway, clothesline and landscaping to front and rear yards



Artist impression only.



GROUND FLOOR PLAN

FIRST FLOOR PLAN

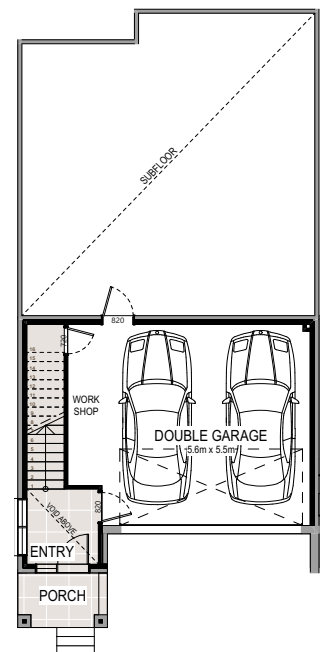

GARAGE PLAN



creationhomes

Disclaimer: These are preliminary, indicative floorplans, subject to planning and other approvals. Please note that these floorplans were produced prior to completion of construction. Location and extent of facade, elements, fittings, finishes and specifications are approximate only & subject to change without notice in accordance with the provisions of the Contract of Sale or where required for compliance, planning, building regulations, other laws or for any other reason. All images are for illustrative purposes only. The furniture depicted is not included with any sale. Prospective purchasers must make & only rely on their own assessments & seek their own professional advice in all respects. *Fixed price for standard site costs only. All designs are copyright to Creation Homes Pty Ltd. Builders Licence No. 286729C. Prepared July 2023.



PARADE

PEMULWUY

LOT 5-13

PARKER
CONTEMPORARY



LOT AREA 398m²
HOUSE AREA 252m²

KEY INCLUSIONS

- 2590mm high ceilings to ground floor, 2440mm to first floor
- Hybrid timber look flooring to ground floor living, dining, kitchen, entry and hallway
- 20mm stone benchtops throughout
- Miele appliances
- Dual zone ducted reverse cycle air-conditioning
- LED downlights throughout (excluding bedroom)
- Driveway, clothesline and landscaping to front and rear yards



Artist impression only.

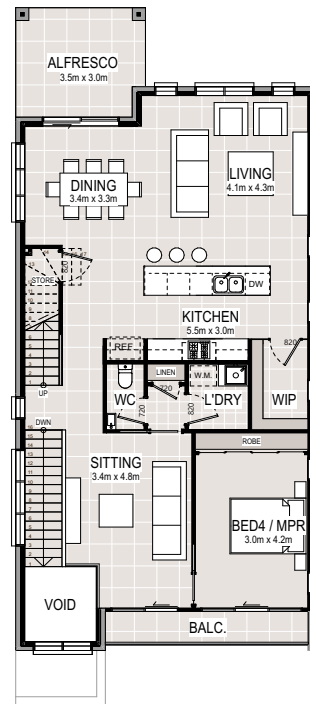

GROUND FLOOR PLAN

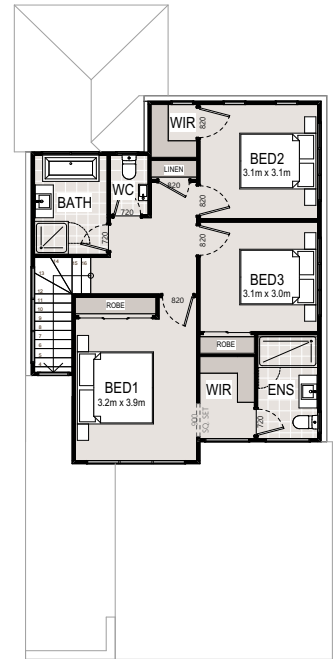

FIRST FLOOR PLAN

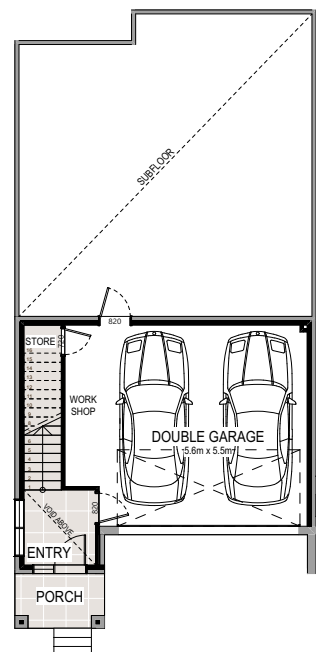

GARAGE PLAN



creationhomes

Disclaimer: These are preliminary, indicative floorplans, subject to planning and other approvals. Please note that these floorplans were produced prior to completion of construction. Location and extent of facade, elements, fittings, finishes and specifications are approximate only & subject to change without notice in accordance with the provisions of the Contract of Sale or where required for compliance, planning, building regulations, other laws or for any other reason. All images are for illustrative purposes only. The furniture depicted is not included with any sale. Prospective purchasers must make & only rely on their own assessments & seek their own professional advice in all respects. *Fixed price for standard site costs only. All designs are copyright to Creation Homes Pty Ltd. Builders Licence No. 286729C. Prepared July 2023.



PARADE

PEMULWUY

LOT 5-14

MACLEAN
TRADITIONAL



LOT AREA 367m²
HOUSE AREA 253.55m²

KEY INCLUSIONS

- 2590mm high ceilings to ground floor, 2440mm to first floor
- Hybrid timber look flooring to ground floor living, dining, kitchen, entry and hallway
- 20mm stone benchtops throughout
- Miele appliances
- Dual zone ducted reverse cycle air-conditioning
- LED downlights throughout (excluding bedroom)
- Driveway, clothesline and landscaping to front and rear yards



Artist impression only.

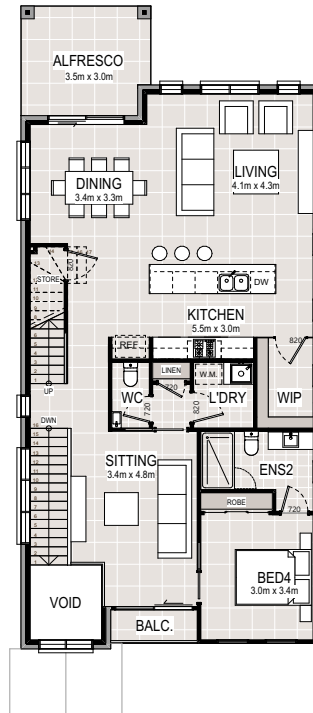

GROUND FLOOR PLAN

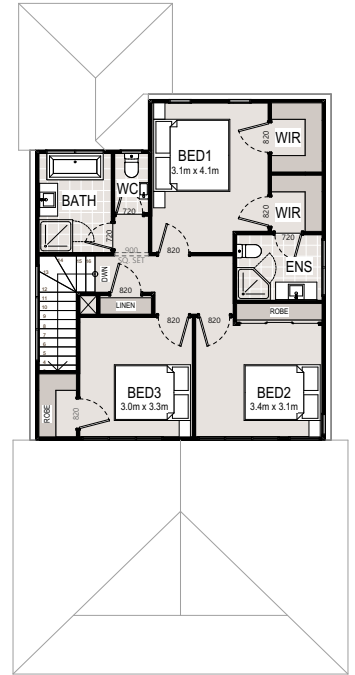

FIRST FLOOR PLAN

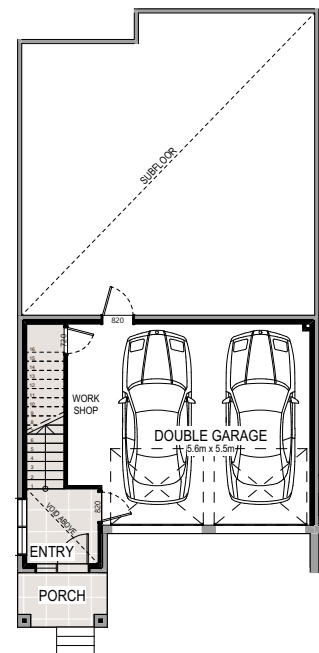

GARAGE PLAN



Disclaimer: These are preliminary, indicative floorplans, subject to planning and other approvals. Please note that these floorplans were produced prior to completion of construction. Location and extent of facade, elements, fittings, finishes and specifications are approximate only & subject to change without notice in accordance with the provisions of the Contract of Sale or where required for compliance, planning, building regulations, other laws or for any other reason. All images are for illustrative purposes only. The furniture depicted is not included with any sale. Prospective purchasers must make & only rely on their own assessments & seek their own professional advice in all respects. *Fixed price for standard site costs only. All designs are copyright to Creation Homes Pty Ltd. Builders Licence No. 286729C. Prepared July 2023.



PARADE

PEMULWUY

LOT 5-15

MILLER
MODERN



LOT AREA 352m²
HOUSE AREA 253.68m²

KEY INCLUSIONS

- 2590mm high ceilings to ground floor, 2440mm to first floor
- Hybrid timber look flooring to ground floor living, dining, kitchen, entry and hallway
- 20mm stone benchtops throughout
- Miele appliances
- Dual zone ducted reverse cycle air-conditioning
- LED downlights throughout (excluding bedroom)
- Driveway, clothesline and landscaping to front and rear yards



Artist impression only.

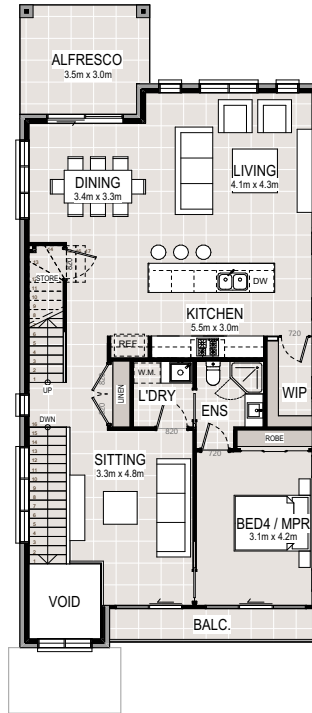

GROUND FLOOR PLAN

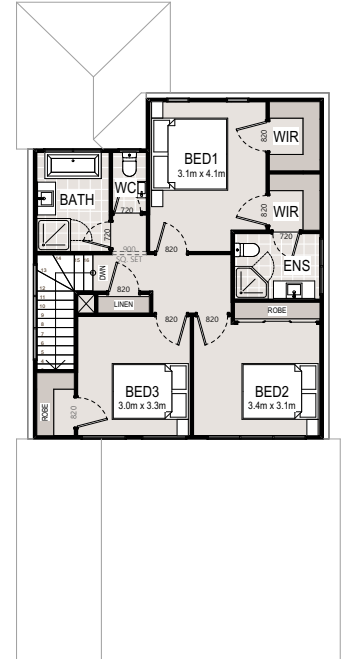

FIRST FLOOR PLAN

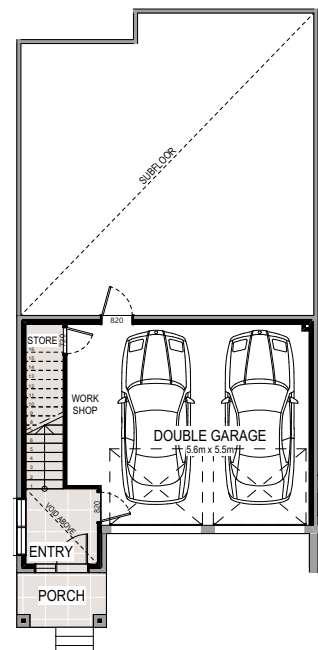

GARAGE PLAN



creationhomes

Disclaimer: These are preliminary, indicative floorplans, subject to planning and other approvals. Please note that these floorplans were produced prior to completion of construction. Location and extent of facade, elements, fittings, finishes and specifications are approximate only & subject to change without notice in accordance with the provisions of the Contract of Sale or where required for compliance, planning, building regulations, other laws or for any other reason. All images are for illustrative purposes only. The furniture depicted is not included with any sale. Prospective purchasers must make & only rely on their own assessments & seek their own professional advice in all respects. *Fixed price for standard site costs only. All designs are copyright to Creation Homes Pty Ltd. Builders Licence No. 288729C. Prepared July 2023.



PARADE

PEMULWUY

LOT 5-18

CARTER
WITH BALCONY



LOT AREA 379m²
HOUSE AREA 253m²

KEY INCLUSIONS

- 2590mm high ceilings to ground floor, 2440mm to first floor
- Hybrid timber look flooring to ground floor living, dining, kitchen, entry and hallway
- 20mm stone benchtops throughout
- Miele appliances
- Dual zone ducted reverse cycle air-conditioning
- LED downlights throughout (excluding bedroom)
- Driveway, clothesline and landscaping to front and rear yards



Artist impression only.

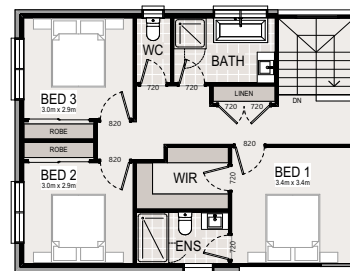

FIRST FLOOR PLAN

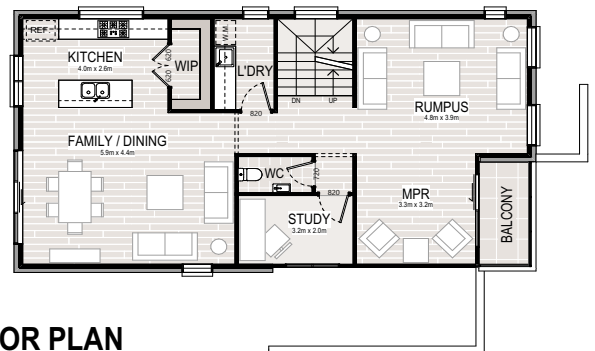

GROUND FLOOR PLAN

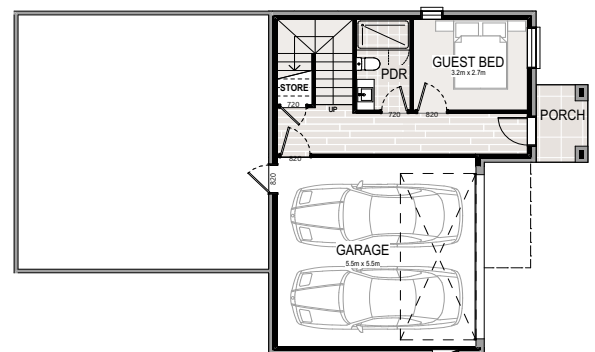

LOWER GROUND FLOOR PLAN



creationhomes

Disclaimer: These are preliminary, indicative floorplans, subject to planning and other approvals. Please note that these floorplans were produced prior to completion of construction. Location and extent of facade, elements, fittings, finishes and specifications are approximate only & subject to change without notice in accordance with the provisions of the Contract of Sale or where required for compliance, planning, building regulations, other laws or for any other reason. All images are for illustrative purposes only. The furniture depicted is not included with any sale. Prospective purchasers must make & only rely on their own assessments & seek their own professional advice in all respects. *Fixed price for standard site costs only. All designs are copyright to Creation Homes Pty Ltd. Builders Licence No. 288729C. Prepared July 2023.

DESIGNED TO DELIGHT

LIVE IN EVERYDAY
LUXURY, SURROUNDED
BY BOTH NATURAL
AND ARCHITECTURAL
BEAUTY.

A conscious combination of materials work together to produce Parade's ultra stylish street appeal. The mixed use of brickwork, timber, painted cladding and Colorbond® ensures each brand new home stands alone in its character.



INCLUSIONS

Turnkey Specifications Inclusions Schedule

Walls *

Combination of any of the following, as nominated:

- Face brickwork
- Rendered masonry and/ or lightweight masonry
- Painted selected lightweight cladding
- Natural and/or reconstituted stone
- Timber

Roofing

- Concrete roof tiles selected from standard range or pre-finished Colorbond® metal roofing for low pitched roofs as per plan.

Windows

- Aluminium awning and/or sliding with keyed alike locks to each opening sash
- Decor satin (obscure glaze) to ensuite, bathroom & WC windows and clear glazing to balance unless specified otherwise by local authorities or planning requirements.

Front Door*

- Painted finish (920 wide, 2040 high) hinged door with clear glazing (subject to design allowance).

Front Door Frame*

- Painted finish with clear glazing to sidelight (where applicable).

Front Porch Ceiling

- Selected sheeting.

Front Garage Doors

- Sectional overhead Colorbond® door with auto opener, two hand-held and one wall mounted transmitter.

Inclusions may vary depending on House Design, Selected External/Internal Colour Schemes & Material,

*Authority Requirements & Approvals, Site Conditions and are not redeemable for cash or credit at contract.

Credits will not be given for the deletion of any inclusion. Creation Homes inclusions specification is subject to change without notice and we reserve the right to substitute items with equivalent products at any time and to use alternative suppliers other than where specified in the contract. Creation Homes (NSW) Pty Ltd Builder

License No: 286729C; Version **November 2021**.

INCLUSIONS

Turnkey Specifications Inclusions Schedule

EXTERIOR FINISHES

Fascia & Gutter

- Colorbond® fascia, gutters and box gutters.
- Colorbond® rain heads and PVC downpipes.

Entry Porch

- External first quality ceramic tiles.

Driveway*

- Cove finished coloured concrete with colour seal.

Fencing

- Boundary fence *Colorbond® OR* *Subject to *Authority Requirements & Estate Guidelines*.

Letterbox*

- Brick or Pre-cast concrete render (Subject to Authority and Estate Guidelines).

Rear Terrace/ Alfresco

- Broom finished concrete

Landscaping*

- Landscaping to front and rear yards including a combination of turf and mulched garden beds (according to development landscape requirements).

Inclusions may vary depending on House Design, Selected External/Internal Colour Schemes & Material, *Authority Requirements & Approvals, Site Conditions and are not redeemable for cash or credit at contract. Credits will not be given for the deletion of any inclusion. Creation Homes inclusions specification is subject to change without notice and we reserve the right to substitute items with equivalent products at any time and to use alternative suppliers other than where specified in the contract. Creation Homes (NSW) Pty Ltd Builder License No: 286729C; Version **November 2021**.

INCLUSIONS

Turnkey Specifications Inclusions Schedule

INTERIOR FINISHES

Floor Coverings

- First quality Hybrid timber flooring from selected Creation Homes standard range to ground floor living, dining, kitchen & hallways.
- First quality ceramic tiles to all wet areas.
- 100% first grade quality carpet on superior grade foam underlay to all remaining areas.

Walls

- Plasterboard with low sheen 3 coat paint finish.

Ceilings

- Plasterboard with 3 coat paint finish

Wall Tiling

- Bath & Ensuite - All walls tiled to 1200mm with 2100mm in showers
- Splashback in laundry.
- Skirting tiles to laundry, powder room & WC where applicable.

Doors & Woodwork

- Gloss paint finish to flush panel internal doors, skirtings and architraves, internal doors 2040mm high with cushion door stops as required.

Cornice

- 900mm Cove cornices

Thermal Insulation

- A required to meet thermal rating.

Woodwork

- 68 x 19 DAR Pine architrave and 92 x 19 DAR Pine skirting, both in gloss painted finish.

Ceiling Height

- Ground Floor 2490mm (subject to statutory requirements).

Inclusions may vary depending on House Design, Selected External/Internal Colour Schemes & Material, *Authority Requirements & Approvals, Site Conditions and are not redeemable for cash or credit at contract. Credits will not be given for the deletion of any inclusion. Creation Homes inclusions specification is subject to change without notice and we reserve the right to substitute items with equivalent products at any time and to use alternative suppliers other than where specified in the contract. Creation Homes (NSW) Pty Ltd Builder License No: 286729C; Version **November 2021**.

INCLUSIONS

Turnkey Specifications Inclusions Schedule

FIXTURES & FITTINGS

KITCHEN

Cabinets

- Fully lined melamine carcass.

Doors & Drawers

- Laminated finish with soft close drawers in accordance with selected colour scheme.

Benchtops

- Reconstituted stone - 20mm thick with square edging.

Splashback

- Ceramic tile splashback in accordance with selected colour scheme.

Sink

- Stainless steel double bowl under-mount sink.

Tapware

- Chrome finish sink mixer with built-in filtration system and hand-held spray attachment.

Dishwasher Space

- 650mm wide space provided for dishwasher.

Oven

- 1 x Technika 600mm stainless steel electric oven.

Cooktop

- Technika 900mm gas (subject to design allowance) stainless steel with wok-burner & cast-iron trivets*.

Rangehood

- Technika 900mm wide ducted rangehood (subject to design allowance).

Microwave Space

- Integrated into cabinets.

Inclusions may vary depending on House Design, Selected External/Internal Colour Schemes & Material, *Authority Requirements & Approvals, Site Conditions and are not redeemable for cash or credit at contract. Credits will not be given for the deletion of any inclusion. Creation Homes inclusions specification is subject to change without notice and we reserve the right to substitute items with equivalent products at any time and to use alternative suppliers other than where specified in the contract. Creation Homes (NSW) Pty Ltd Builder License No: 286729C; Version **November 2021**.

INCLUSIONS

Turnkey Specifications Inclusions Schedule

FIXTURES & FITTINGS

LAUNDRY

House specific

Freestanding

- 45 litre laundry trough and cabinet.

OR

Built-in joinery

- Stainless steel 45 litre inset trough on cabinet with fully lined melamine carcass, laminated doors and reconstituted stone 20mm thick to match kitchen.

Tapware

- Chrome finish sink mixer.
- Chrome finish washing machine stops.

POWDER ROOM

Toilet Suite

- Vitreous china wall flush toilet suite with soft close seat.

Basin

House specific

- Vitreous china wall hung hand basin or fully laminated vanity unit with semi recessed basin and laminated doors.

Tapware

- Chrome finish mixer to finish.

Towel Ring

- Chrome finish.

Inclusions may vary depending on House Design, Selected External/Internal Colour Schemes & Material, *Authority Requirements & Approvals, Site Conditions and are not redeemable for cash or credit at contract. Credits will not be given for the deletion of any inclusion. Creation Homes inclusions specification is subject to change without notice and we reserve the right to substitute items with equivalent products at any time and to use alternative suppliers other than where specified in the contract. Creation Homes (NSW) Pty Ltd Builder License No: 286729C; Version **November 2021.**

INCLUSIONS

Turnkey Specifications Inclusions Schedule

FIXTURES & FITTINGS

POWDER ROOM

Mirror

- Polished edges.

Exhaust fan

- Ceiling mounted.

Toilet roll holder

- Chrome finish.

BATHROOM

Shower screen

- 2000mm high semi-frameless with clear glass.

Toilet

- Vitreous china wall flush toilet suite with soft close seat.

Shower base

- Tiled with chrome floor to waste.

Mirror

- Polished edges.

Exhaust Fan

- Ducted and ceiling mounted.

Vanity

- Fully lined melamine carcass.

Doors and Drawers

- Laminated finish with soft close drawers in accordance with selected colour scheme.

Inclusions may vary depending on House Design, Selected External/Internal Colour Schemes & Material, *Authority Requirements & Approvals, Site Conditions and are not redeemable for cash or credit at contract. Credits will not be given for the deletion of any inclusion. Creation Homes inclusions specification is subject to change without notice and we reserve the right to substitute items with equivalent products at any time and to use alternative suppliers other than where specified in the contract. Creation Homes (NSW) Pty Ltd Builder License No: 286729C; Version **November 2021.**

INCLUSIONS

Turnkey Specifications Inclusions Schedule

FIXTURES & FITTINGS

BATHROOM

Benchtops

- Reconstituted stone - 20mm thick with square edge.

Basin

House specific

- Vitreous china inset basin.

Bath

- Acrylic (where applicable).

Shower Rose

- Shower with hand held and adjustable shower head on rail.

Towel Rail

- Double rail in chrome finish.

Toilet roll holder

- Chrome finish.

ENSUITE

Shower Screen

- 2000mm high semi-frameless with clear glass.

Toilet

- Vitreous china wall flush toilet suite with soft close seat.

Shower base

- Tiled with chrome floor waste.

Mirror

- Polished edges.

Inclusions may vary depending on House Design, Selected External/Internal Colour Schemes & Material, *Authority Requirements & Approvals, Site Conditions and are not redeemable for cash or credit at contract. Credits will not be given for the deletion of any inclusion. Creation Homes inclusions specification is subject to change without notice and we reserve the right to substitute items with equivalent products at any time and to use alternative suppliers other than where specified in the contract. Creation Homes (NSW) Pty Ltd Builder License No: 286729C; Version **November 2021**.

INCLUSIONS

Turnkey Specifications Inclusions Schedule

FIXTURES & FITTINGS

ENSUITE

Exhaust fan

- Ducted and ceiling mounted.

Vanity

- Fully lined melamine carcass.

Doors and Drawers

- Laminated finish with soft close drawers in accordance with selected colour scheme.

Benchtops

- Reconstituted stone - 20mm thick with square edge.

Basin

- Vitreous china inset basin.

Bath

- Acrylic (where applicable).

Shower Rose

- Shower with hand held and adjustable shower head on rail.

Towel Rail

- Double in chrome finish.

Toilet Roll Holder

- Chrome finish.

Inclusions may vary depending on House Design, Selected External/Internal Colour Schemes & Material, *Authority Requirements & Approvals, Site Conditions and are not redeemable for cash or credit at contract. Credits will not be given for the deletion of any inclusion. Creation Homes inclusions specification is subject to change without notice and we reserve the right to substitute items with equivalent products at any time and to use alternative suppliers other than where specified in the contract. Creation Homes (NSW) Pty Ltd Builder License No: 286729C; Version **November 2021.**

INCLUSIONS

Turnkey Specifications Inclusions Schedule

FIXTURES & FITTINGS

BEDROOMS

Wardrobe

- Mirrored sliding robe doors.
- Melamine shelf with hanging rail.

Main Bedroom

- Walk-in robe - where applicable.
- Melamine shelf with hanging rail.

GENERAL

Heating/Cooling

- Actron Ducted Reverse Cycle Heating/ Cooling System.

Connectivity

- Basic Optical Smart Wire System for Data, Telephone and TV.

Clothesline

- Wall or ground mounted folding clothesline (dependent on house design).

Door Bell

- Hard wired door bell.

Entry Door Handle

- Chrome finish mechanical entrance lever set.

External sliding doors

- Latch and key.

Rainwater Tank

- 2000 litre rainwater tank as standard, where required. Subject to BASIX Assessment.

Inclusions may vary depending on House Design, Selected External/Internal Colour Schemes & Material, *Authority Requirements & Approvals, Site Conditions and are not redeemable for cash or credit at contract. Credits will not be given for the deletion of any inclusion. Creation Homes inclusions specification is subject to change without notice and we reserve the right to substitute items with equivalent products at any time and to use alternative suppliers other than where specified in the contract. Creation Homes (NSW) Pty Ltd Builder License No: 286729C; Version **November 2021**.

INCLUSIONS

Turnkey Specifications Inclusions Schedule

GENERAL

Internal door furniture

- Chrome finish lever passage set.

Main Bathroom, Ensuite, Powder Room

- Passage set with privacy latches.

Internal Light Fittings

- LED downlights to kitchen & bathroom areas, oyster lights to remaining areas,
- Fluorescent light fitting to Garage.

Electrical Switch Plates

- Clipsal Classic in white finish or similar.

Hot Water Unit

- Instantaneous gas hot water system.

Preliminary Works

- Building Permit application fees.
- Drafting of standard customer construction drawings.
- Temporary fencing and scaffolding during construction as required.
- Geo-fabric sediment control & waste receptacle as required by local council during construction.

Site Works

- Stormwater and sewer drainage to legal point of discharge and sewer connection point respectively.
- Connection to mains power supply including conduit & cabling for underground connection of single-phase electricity to meter box and electricity supply charge during construction.
- Connection of underground gas and water supply including metering.
- Standard Site Works (based on balance cut and fill for non-sloping lots).

Features

- Energy rating to comply with BASIX requirements.
- Professionally prepared interior and exterior colour schemes.
- Three months maintenance warranty.
- Engineer certified concrete slab.
- Prefabricated wall frames and engineer designed roof trusses.

Note: Additional Site Works and BASIX requirements may be applicable to your lot. Additional costs may be subject to sewer, acoustic, site contour and survey reports, delays to registration and development covenants. Please consult your agent for further detail.



PARADE

PEMULWUY

paraderesidences.com.au